

Coffee Buzz



Finished size: 54" x 65"

Featuring the
Coffee Buzz Collection
by Kathy Hall

Quilt designed by Jean Ann Wright



makower uk[®]

1384 Broadway • New York, NY 10018
(800) 223-5678 • www.andoverfabrics.com

Coffee Buzz Quilt

Introducing Andover Fabrics new collection: Coffee Buzz by Kathy Hall

Quilt designed by Jean Ann Wright

Quilt finishes 54" x 65"

12 Pieced Blocks: 10" x 10"

Planning

Love coffee? Have a friend who does? The novelty prints in this quilt pay homage to those endless cups of coffee. Fussy-cut the block centers to make each square different. The Attic Window block can be a bit tricky due to the mitered corner, so follow directions carefully. Be sure to stop for a coffee break every now and then.

Fabric Requirements & Cutting Directions

Note: Mitered outer borders include 4" extra length.

***4351-T** 1¼ yards **Coffee Cup Print (middle border)**

Cut (2) borders 5½" x 69", cut crosswise and pieced

Cut (2) borders 5½" x 58", cut crosswise and pieced

4352-T ¾ yard **People Print (block center)**

Cut (12) 7½" x 7½" squares

4353-N ¾ yard **Plaid (outer border)**

Cut (2) borders 3½" x 69", cut crosswise and pieced

Cut (2) borders 3½" x 58", cut crosswise and pieced

4354-N ¾ yard **Brown/Gold Dots (inner border)**

Cut (2) borders 2½" x 69", cut crosswise and pieced

Cut (2) borders 2½" x 58", cut crosswise and pieced

4355-N ¾ yard **Dark Spirals Print (blocks)**

Cut (12) 2½" x 10½" rectangles

4355-O ¾ yard **Light Spirals Print (blocks)**

Cut (12) 2½" x 10½" rectangles

1867-R8 ½ yard **Red Dimples (coffee cups)**

Cut (12) coffee cups with handles

1867-T2 1 yard **Teal Dimples (blocks, binding)**

Cut (6) strips 2½" x width of fabric (approx. 42")
for binding

Cut (24) 1½" x 10½" rectangles

1867-L2 ½ yard **Light Cream Dimples (sashes)**

Cut (5) 1½" x 34½" long sashes

Cut (16) 1½" x 10½" short sashes

***Additional fabric required for backing.**

***4351-T** 3½ yards **Coffee Cup Print (backing)**

Cut and piece to fit quilt top with 4" overlap on all sides.

Making the Attic Window Blocks

1. Cut the 12 people print 7½" squares from different parts of the fabric so that each block center is different. Sew a 1½" x 10½" teal strip to each light or dark spiral print strip. Mark a dot in the bottom left corner of each 7½" square that is ¼" away from the left and bottom sides (the "stop spot"). Align the end of the teal/light spiral strip with the top left corner of a 7½" square. The teal strip should touch the square. Working with the square on top so that you can see the dot, stitch the strip in place, stopping stitching at the stop spot; backstitch (Diagram 1).

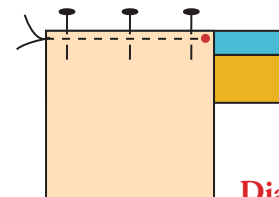

Diagram 1

2. Align a teal/dark spiral strip with the bottom right corner of the square. Working with the square on top, begin stitching at the dot and stitch to the outer edge (Diagram 2). Press the seam allowances toward the coffee cup square.

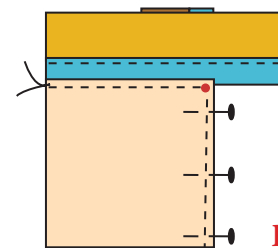

Diagram 2

Coffee Buzz Quilt

3. Fold the block diagonally with right sides together, and align the teal/spiral strips. Pin the ends together. If it is easier, finger press the seams of the underneath strips away from the coffee cup square so that the front and underneath seams “butt” with each other. Align a ruler with the folded diagonal of the square and the outer corner of the strips and mark a sewing line on the strips (Diagram 3). Sew the strips together from the stop spot to the outside edge corner (Diagram 4). Trim the excess from the seam. Press the seam open. Check that the miter lies flat on the front. Repeat to make 12 blocks.

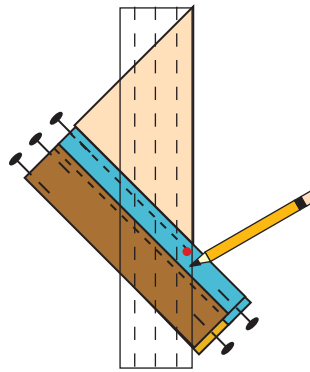

Diagram 3

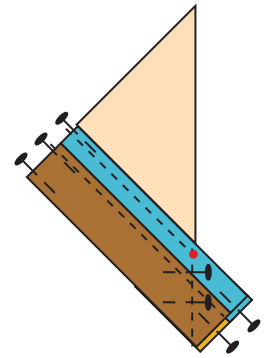

Diagram 4

4. Prepare the coffee cups with your favorite method of applique. The cups shown on the quilt are fused. Finish the edges of the applique as you wish.

Quilt Assembly

5. Refer to the Quilt Diagram throughout the quilt assembly. Sew 3 blocks between 4 short light cream sashes, keeping the orientation of the blocks correct. Press the seam allowances toward the sashes. Make 4 block rows.
6. Sew the block rows alternately with 5 long light cream sashes. Press seam allowances toward the long sashes.
7. Sew a coffee cup print border strip between a brown/gold dot border and a plaid border of the same length. Repeat for all border strips. Sew long border units to sides, stopping stitching $\frac{1}{4}$ " from corners of quilt. Sew short border units to top and bottom. Miter the corners, trim the excess, and press seam allowances to one side.

Finishing the Quilt

8. Layer quilt with batting and backing. Quilt in the ditch around borders and block patches. Quilt around the printed motifs in the people print squares in the blocks and the coffee cup border. Bind to finish the quilt.



Coffee Cup Template

Coffee Buzz Quilt

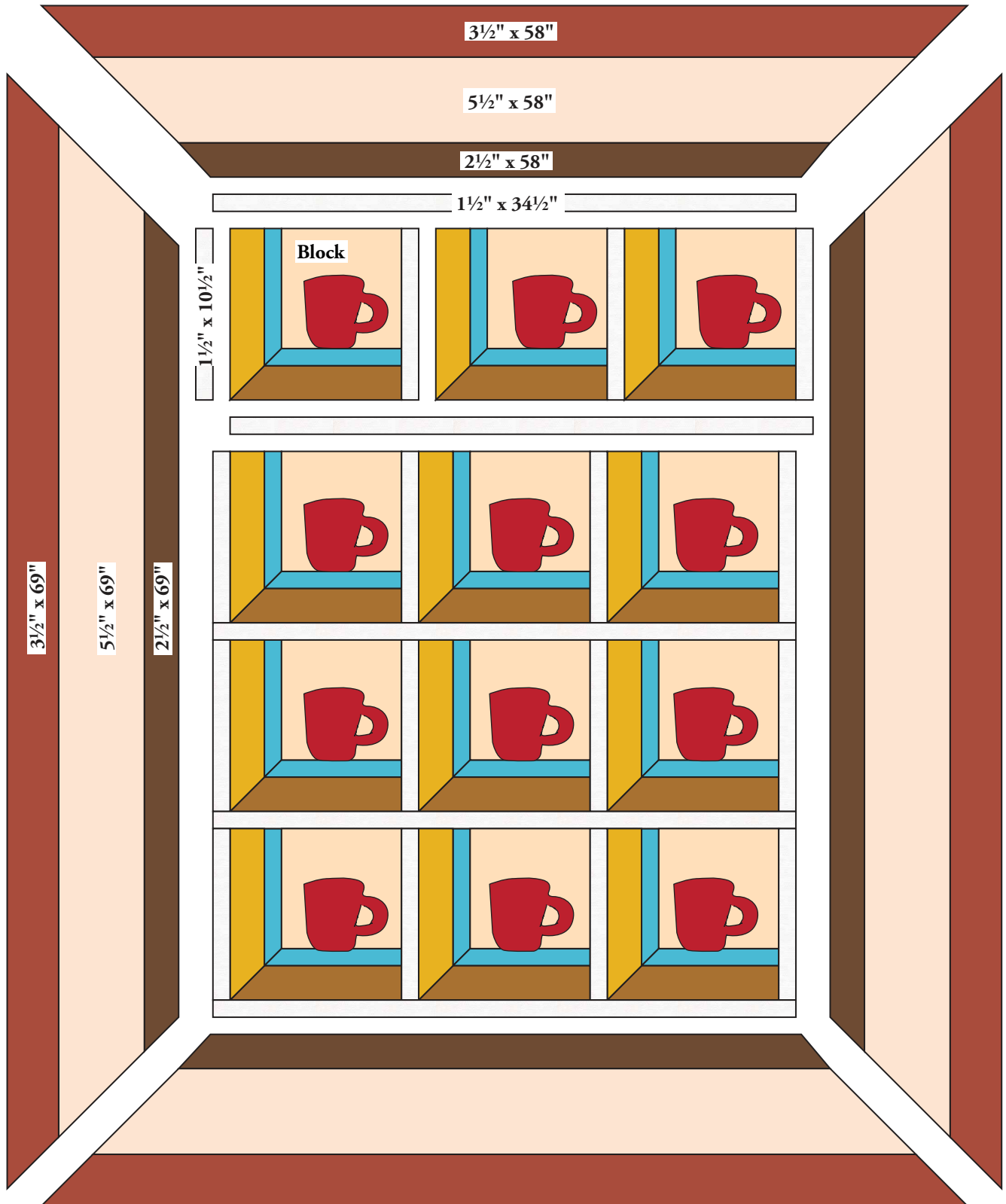

Quilt Diagram

1384 Broadway
 New York, NY 10018
 (800) 223-5678
 www.andoverfabrics.com

Coffee Buzz

by Kathy Hall



4351-T*



4352-T*



4353-N*

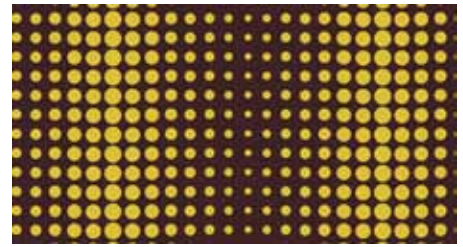

4354-N*



4355-0*



4355-N*

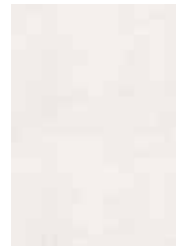

1867-L2*



1867-T2*



1867-R8*



4351-LK



4352-LK



4353-LK



4353-K

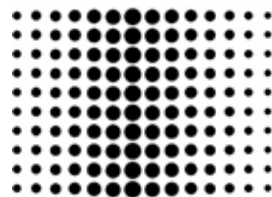

4354-LK

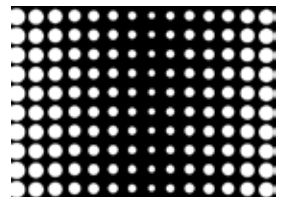

4354-K



4351-K



4352-K



4355-LK



4355-K



1867-AK



1867-K2

*Indicates fabric used in quilt pattern. Fabrics shown are 30% of actual size.