

Octosaurus Rex

Finished size 60" x 72" (1.52m x 1.83m)

Designed by Judith Hollies of justjude-designs.com
using the Rex collection from Makower UK www.makoweruk.com



makower uk

Unit 14, Cordwallis Business Park, Clivemont Road,
Maidenhead, Berkshire SL6 7BU +44(0)1628 509640
sales@makoweruk.com www.makoweruk.com

 **andover**

Octosaurus Rex

Finished size 60" x 72" (1.52m x 1.83m)

Designed by Judith Hollies of justjude-designs.com

using the Rex collection from Makower UK www.makoweruk.com

Fabric Requirements

Fabric	Code	Amount
Fabric 1	1894/T Placement	50cms / $\frac{5}{8}$ yd
Fabric 2	1897/B Skeleton	1.20 m / $1\frac{1}{3}$ yds
Fabric 3	1898/Q Palm Trees	90cms / 1 yd
Fabric 4	1896/T Mini Scatter	2.10cm (front) / $2\frac{1}{3}$ yds 3.50m (back) / $3\frac{7}{8}$ yds
Fabric 5	1895/T Scenic	60cm / $\frac{2}{3}$ yd
Fabric 6	1898/T Palm Trees	1.40m / $1\frac{5}{8}$ yd
Fabric 7	1899/S Wavy Stripe	50cms / $\frac{5}{8}$ yd
Wadding	1.75m / 2yds minimum width of 203cm / 80"	
Large sheet of template plastic; Cut 1 x 4.5" square and trace and cut Templates A, B & E		
Other	Basting Spray 505, 4.5" & 12.5" square rulers	

Notes:

- Read the pattern in full before starting.
- Scant $\frac{1}{4}$ " seams are used throughout except where stated otherwise.
- Take care when cutting out directional prints
- Press after each seam to the darkest side unless advised otherwise.
- WOF - width of fabric - a strip of fabric cut from selvedge to selvedge.
- Make sure to visit <http://www.makoweruk.com/projects/> to ensure you are working from the most up-to-date version of the pattern.

Cutting Instructions

Fabric 1 (Rex Placement 1894-T) :

Use the 4.5" square of template plastic to cut out 15 fussy cut dinosaurs

Fabric 2 (Skeleton 1897-B):

Cut 7 x 1 $\frac{7}{8}$ " strips width of fabric. Sub cut these into 60 x (1 $\frac{7}{8}$ " x 4.5") – Block A, section B
Cut 8 x 2 $\frac{3}{8}$ " strips width of fabric. Sub cut these into 120 x (2 $\frac{3}{8}$ " x 2.5"). Then apply template E to these pieces – Block A, section E
Cut 4 x 2 $\frac{3}{8}$ " strips width of fabric. Sub cut these into 60 x (2 $\frac{3}{8}$ " x 2.5"). Then apply template E to these pieces – Block B, section E

Fabric 3 (Palm Trees 1898-Q):

Cut 6 x 1 $\frac{7}{8}$ " strips width of fabric. Sub cut these into 120 x 1 $\frac{7}{8}$ " squares, then cut them in half diagonally – Block A, section F
Cut 7 x 1 $\frac{7}{8}$ " strips width of fabric. Sub cut these into 60 x (1 $\frac{7}{8}$ " x 4.5") – Block A, section C
Cut 4 x 1 $\frac{7}{8}$ " strips width of fabric. Sub cut these into 60 x 1 $\frac{7}{8}$ " squares, then cut them in half diagonally – Block B, section F

Fabric 4 (Mini Scatter 1896-T):

Cut 7 x 1 $\frac{7}{8}$ " strips width of fabric. Sub cut these into 60 x (1 $\frac{7}{8}$ " x 4.5") – Block A, section D
Cut 10 x 2 $\frac{3}{8}$ " strips width of fabric. Sub cut these into 60 x (2 $\frac{3}{8}$ " x 6.5") – Block A, section G
Cut 2 x 1 $\frac{7}{8}$ " strips width of fabric. Sub cut these into 15 x (1 $\frac{7}{8}$ " x 3.5") – Block B, section B1
Cut 15 x 1 $\frac{7}{8}$ " strips width of fabric. Sub cut these into 90 x (1 $\frac{7}{8}$ " x 6.5") – Block B, section B2-7
Cut 4 x 1 $\frac{7}{8}$ " strips width of fabric. Sub cut these into 15 x (1 $\frac{7}{8}$ " x 9.5") – Block B, section B8

Fabric 5 (Scenic 1895-T):

Cut 3 x 7.25" strips width of fabric. Sub cut these into 15 x 7.25" squares. Then apply template A to these squares – Block B, section A

Fabric 6 (Palm Trees 1898-T):

Cut 7 x 1 7/8" strips width of fabric. Sub cut these into 60 x (1 7/8" x 4.5") – Block B, section C

Cut 15 x 2 3/8" strips width of fabric. Sub cut these into 60 x (2 3/8" x 9.5") – Block B, section D

Fabric 7 (Wavy Stripe 1899-S):

Cut 7 x 2.5" strips width of fabric

Sewing Instructions:

Make Block A (15):

Refer to Fig 1 for layout

1. Join all strips B and D either side of strip C. Press. You will have 60 sets in total. Put to one side.
2. Join triangles F either side of template E as shown in Fig 2. Press.
3. Find the middle of each long side of rectangle G (mark with a pin). Also find the middle of the long edge of the F/E sets from step 2.
4. Join an F/E set either side of section G, by aligning the pin markers. Press. Fig 2
5. Place the 4.5" square ruler on top. Align the corners of the ruler with the corners of section E. Trim off the excess at the opposite corners. You will have 60 of these 4.5" units.
6. Assemble the block in 3 rows: Rows 1 and 3 – join the corner units from step 5 either side of a B/C/D unit (make sure section D is at the top of row 1 and the bottom of row 3). Take care to pin where the same fabrics meet.
7. Row 2 – Join B/C/D units either side of a 4.5" fussy cut dinosaur square (make sure the B sections are next to the centre square).
8. Press the seams of rows 1 and 3 away from the centre, press the seams of row 2 towards the centre square.
9. Join the rows right sides together, taking care to butt/nest the intersecting seams. Square the block to 12.5".

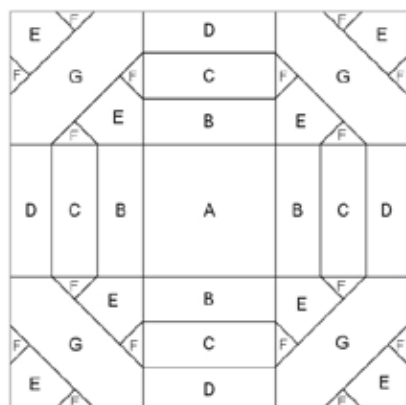

Fig 1

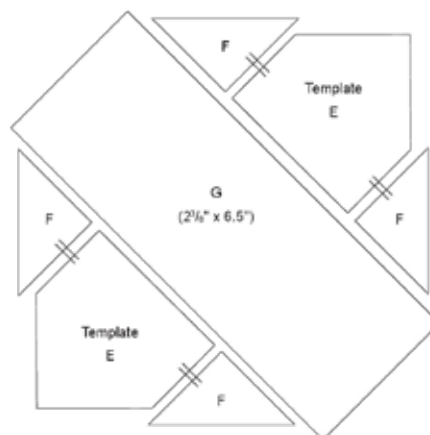

Fig 2

Make Block B (15):

Refer to Fig 3 for layout

1. Join strip B1 to the top edge of the centre octagon. Press
2. Working in a clockwise direction, continue adding B strips 2-7 to the edges of the Octagon, pressing and trimming the excess as you go. See Fig 4
3. Finish the round with strip B8. Press and trim off any excess underneath.
4. Place template B on top and trim.

- Join strips C to the top and sides of the Octagon before adding strips D to the remaining sides, see Fig 5. Trim off the excess from C strips underneath the D strips.
- Place the block on the cutting table. With C strips positioned at the top, bottom and sides, place the 12.5" square ruler on top, aligning the edges of the ruler with the edges of the C strips. Trim off the excess.

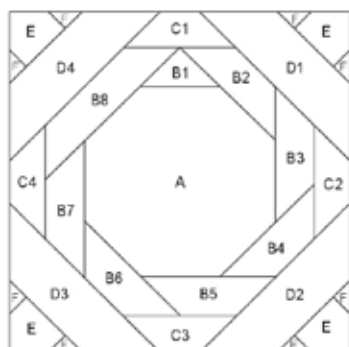

Fig 3

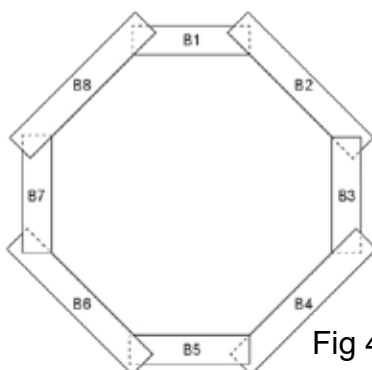

Fig 4

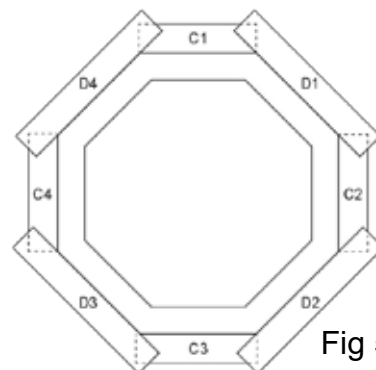

Fig 5

- Make the corner units: Join triangles F either side of template E as shown in Fig 6. Press.
- Join the corner units to the D edges to complete the block (see Fig 7). The block should measure 12.5".

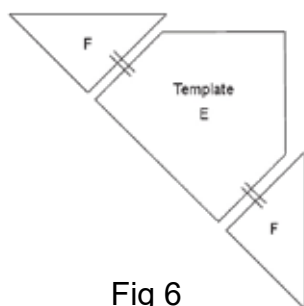

Fig 6

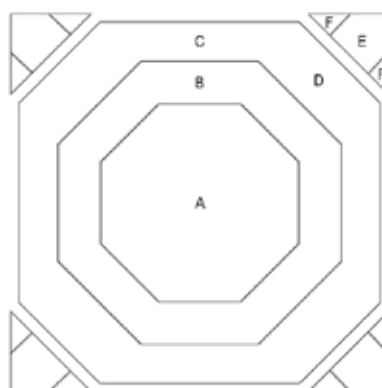

Fig 7

Assemble the quilt top:

- Layout the alternating blocks in 6 rows, with 5 blocks in each row (see original picture).
- Join the blocks right sides together, taking care to pin where the same fabrics meet.
- Press the seams of odd numbered rows in one direction and the seams of even numbered rows in the opposite direction.
- Join the rows right sides together, again taking care to pin where the same fabrics meet, and nesting the intersecting seams.

Basting/Quilting/Binding:

- Bring the short ends of the backing right sides together and separate at the fold. Join the 2 pieces together along the long edge making sure the direction of the prints are the same. Press the seam open.
- Spray baste the quilt top, wadding and backing together and quilt as desired.
- Trim off any excess wadding and backing and square up the quilt if necessary.
- Join the binding strips together, end to end and iron in half widthways, wrong sides together. Attach to the quilt following the double fold method.

REX BLOCK B
(includes seam allowance)

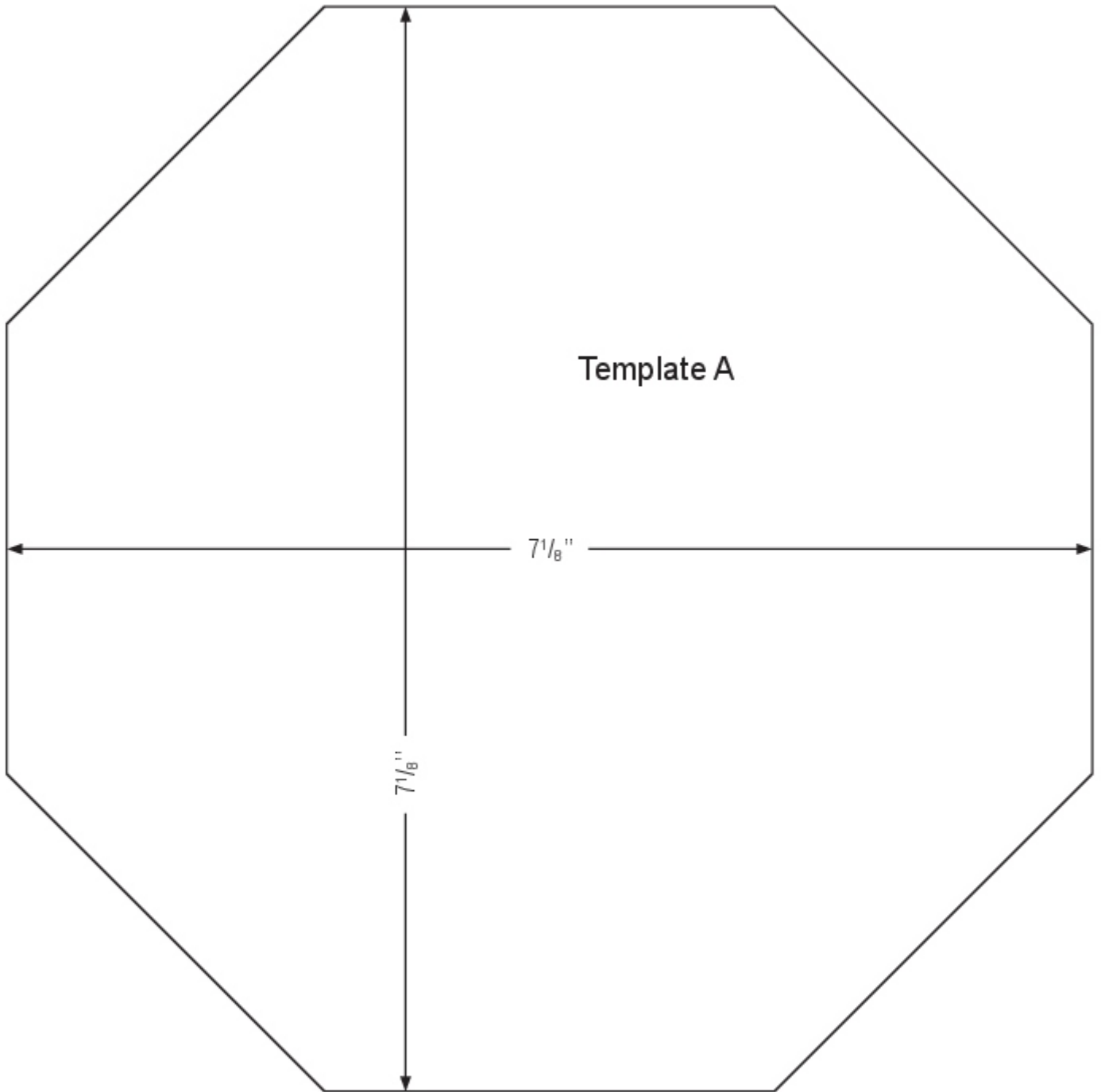

Key:
1 inch

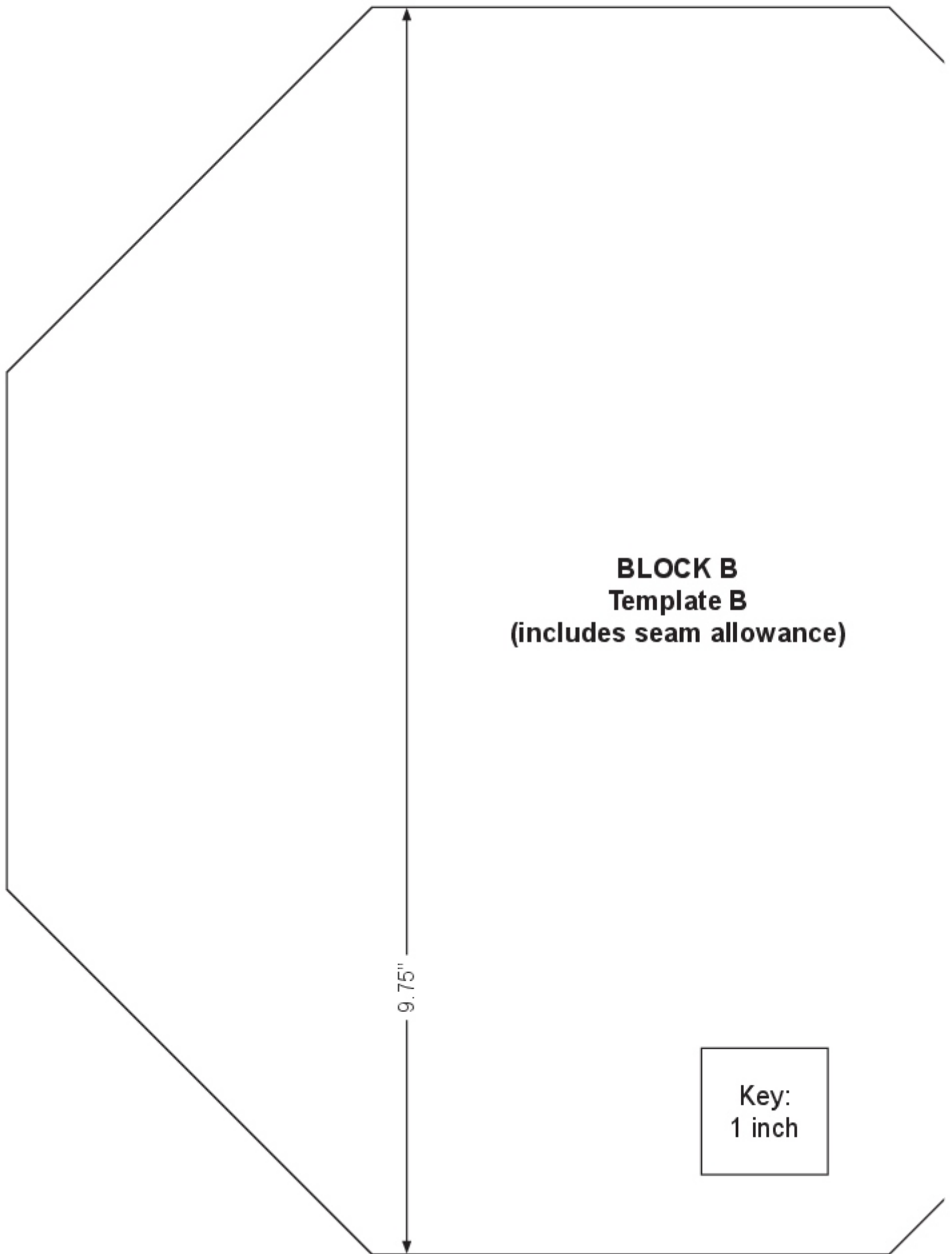

**BLOCK B
Template B
(includes seam allowance)**

9.75"

Key:
1 inch

REX BLOCKS A & B
(includes seam allowance)

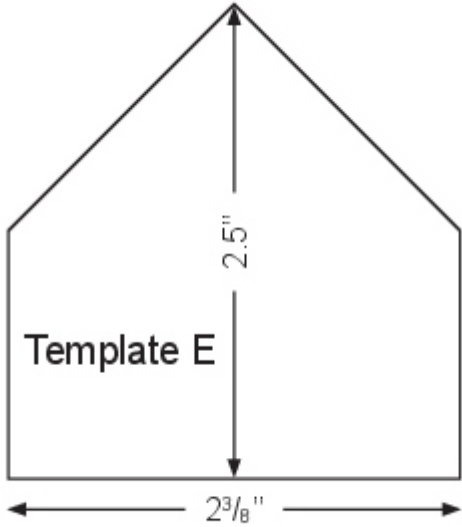
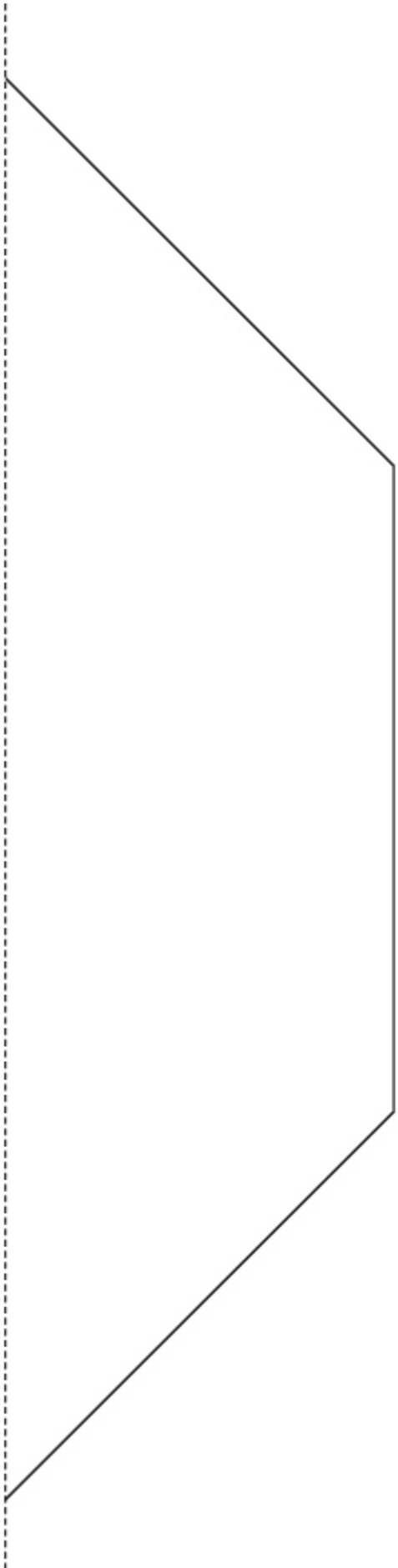

BLOCK B
Join to template B

Key:
1 inch



*1895 T Scenic



1896 Q Mini Scatter



*1896 T Mini Scatter



1894 S Placement



*1894 T Placement



*1899 S Stripe



1897 G Skeleton



*1897 B Skeleton



*1898 Q Palm Trees



*1898 T Palm Trees



Finished size 60" x 72" (1.52m x 1.83m)

Designed by Judith Hollies of justjude-designs.com
using the Rex collection from Makower UK

*designs used in quilt

Download free instructions from www.makoweruk.com