

# Geishas & Ginkgos

BY LONNI ROSSI



Barbara

Lisa

Mari

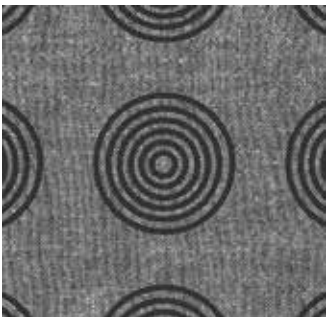

Three Geishas Quilts  
designed by: **Lonni Rossi**

Panel Sizes: **13" x 36"**

[andoverfabrics.com](http://andoverfabrics.com)

## About Geishas & Ginkgos

THE GIRLS ARE BACK! Andover Fabrics and Lonni Rossi have heard their customers ask about the availability of Lonni's Geisha panels that were produced in the past. Now they have brought back those images, along with three coordinating ginkgo motifs in five color ways, all printed on Andover's soft and beautiful Chambray woven cottons.

andover



makower uk  
*The Henley Studio*

Free Pattern Download Available

1384 Broadway New York, NY 10018  
Tel. (800) 223-5678 • [andoverfabrics.com](http://andoverfabrics.com)

# Three Geishas



Introducing Andover Fabrics new collection: **GEISHAS & GINKGOS** by Lonni Rossi

Quilt designed by Lonni Rossi

Each Quilt finishes 13" x 36"

*"Paint" these exotic Oriental figures with fabric and thread using the printed geisha figures as the base for your quilt art. Get as creative as you desire with the unique fabric prints and embellishments.*

## Cutting Directions

**Note:** Read assembly directions before cutting patches. A fat 1/8 is a 9" x 20"-22" cut of fabric. Yardage is sufficient to make three individual wall quilts or to combine the three geishas into one hanging that measures approximately 51" x 36". Read Step 8 for more direction.

### Geisha

Cut (1) geisha (read Steps 1 and 2 before cutting)

### Fabric H, I or K

Cut (1) background rectangle 14" x 30½"

Cut (2) strips 3½" x length of hanging for invisible binding

Cut (2) strips 3½" x width of hanging for invisible binding (read directions for invisible binding before cutting strips)

### Fabric L

Cut patches as needed (Read Step 8)

### Backing

Cut 1 rectangle 20" x WOF

## Additional Cutting for Individual Quilts:

### Cutting for Geisha Barbara

**Fabric C** obi  
**Fabric F** purse  
**Fabric G** kimono parts

### Cutting for Geisha Mari

**Fabric A** under slip  
**Fabric B** kimono  
**Fabric D** fan  
**Fabric E** trim  
**Fabric G** obi, hair trim

### Cutting for Geisha Lisa

**Fabric B** under slip  
**Fabric D** kimono  
**Fabric J** obi

## Fabric Requirements

	Yardage	Fabric
<b>Geisha Print</b>	1 panel (1 yard)	7973-K
<b>Fabric A</b>	underslip fat 1/8 yard	7974-MB
<b>Fabric B</b>	kimono 1/2 yard	7974-MG
<b>Fabric C</b>	obi fat 1/8 yard	7974-MP
<b>Fabric D</b>	fan, kimono 1/2 yard	7974-MR
<b>Fabric E</b>	kimono trim 1/2 yard	7975-B
<b>Fabric F</b>	purse fat 1/8 yard	7976-B
<b>Fabric G</b>	kimono, obi 1/2 yard	7976-P
<b>*Fabric H</b>	background 3/4 yard	A-C-Bluegrass (for Lisa)
<b>*Fabric I</b>	background 3/4 yard	A-C-Gourd (for Mari)
<b>Fabric J</b>	obi fat 1/8 yard	A-C-Marigold
<b>*Fabric K</b>	background 3/4 yard	A-C-Tailor (for Barbara)
<b>Fabric L</b>	border 3/4 yard	A-C-Ebony
<b>Backing</b>	1 3/4 yards	A-C-Linen

\*includes yardage for invisible binding on one quilt

Also needed: 3 yards fusible web for appliqué

Textile paint and textile markers  
(recommended: Pebeo Setacolor)

Sharp embroidery scissors for cutting intricate patches

Fusible thin batt or thin batt and spray adhesive

1. In each hanging, the face and hands are left uncovered. All other parts are either appliquéd with fabric, painted with paint, or embellished with thread painting. Directions here are for fusing fabric patches to the geisha panel. Number each patch on the printed geisha that you plan to cover with fabric.
2. On the fabric geisha panel, draw in the parts of the kimono where it is cut off by the printed rectangle, referring to the quilt photo. Turn the printed fabric geisha over, right side down. Using a light table or window, position fusible webbing (Wonder Under or similar lightweight webbing) on top of the printed geisha, sticky side down. Trace the entire reversed geisha onto the paper side of the fusible web, including the edges of the kimono that you may have added. Do not trace the rectangle. Label the tracing with the same numbers that you wrote on the printed geisha. This will make it easier to place patches.

## Three Geishas

- Carefully cut apart the entire web pattern on the drawn lines. (Do not cut the fabric geisha apart.) Do not cut into or damage adjacent parts when you cut each shape. As you cut each paper template, position and pin it to the same numbered patch on the fabric geisha panel to eliminate confusion later.
- Choose fabrics for each part of the kimono and other patches to be appliquéd. Note that patches are cut without seam allowances so they snug up to each other like a jigsaw puzzle, and they butt up against the printed hands and face. Fuse each web template to the back of the appropriate fabric and cut out along the edge of the web patch. Remove the paper backing. Position each patch on the printed geisha panel, referring to the drawn numbers for placement. Remember that the face and hands are left uncovered. Fuse each patch as it's added. Hint: Begin with the under slips (inside the sleeves or neck), then fuse the kimono folds, the obi, the kimono trim, and finally the fan and hair ornaments.
- Layer the background panel (Fabric H, I, or K), a thin batting, and backing. Using fusible batting or a spray adhesive to keep the batting in place will make the next steps easier.
- Iron a piece of fusible web to the backside of the entire geisha shape. Cut out the shape of the geisha, including the hair ornaments and leaves. Carefully cut away the parts of the panel that are between the leaves on Barbara and Mari. Remove the paper backing. Referring to the quilt photo for placement, fuse the geisha panel to the appropriate background fabric for the geisha you are making.
- To finish the raw edges of the kimono and to indicate fold lines, use a wide satin stitch in a color that closely matches the kimono fabric. Finish the raw edges of other fused fabric patches with a  $\frac{1}{8}$ " or narrower machine satin stitch. Note that you are quilting the piece at the same time that you finish the edges. Here are ideas for embellishing each quilt.



Diagram 1

### Geisha Barbara

\*Black areas that are printed on the panel can be left as they are. If you prefer, the geisha's hair can be filled with black thread, and the sleeves and kimono trim can be embellished with purple thread.

\*Ginkgo leaves are painted with green textile paint or markers.

\*The ginkgo branch in her hand is free-motion quilted with brown thread.

\*The geisha's headpiece is painted with metallic gold textile paint.

\*The under slips at the collar, sleeves, and bottom of the kimono are painted with metallic gold textile paint.

### Geisha Mari and Geisha Lisa

\*Ginkgo leaves are painted with green textile paint or markers.

\*The geisha's chopsticks (head piece) are painted with metallic gold textile paint.

- Square the quilt as needed. Stitch  $3\frac{1}{2}$ " x 14" Fabric L border strips to the top and bottom of the quilt. Trim even with the sides. If you prefer to join the 3 completed geisha panels into one quilt, sew Fabric L  $3\frac{1}{2}$ "-wide sashes between the geishas, and then join Fabric L  $3\frac{1}{2}$ " borders to all sides.

### Finishing the Quilt

- Follow directions to add invisible binding to finish.



# Three Geishas Quilt

## Invisible Binding

These directions are for binding that doesn't show on the front of the quilt. Strips of fabric are stitched around the quilt to make a facing with mitered corners. The entire facing is turned to the back of the quilt. These directions work for any quilt when you want the design to be uninterrupted all the way to the edge of the quilt.

### Step 1

When you have finished quilting, trim the edges of the quilt so all sides are straight and the corners are square.

### Step 2

Measure through the center of your quilt from the top raw edge to the bottom raw edge. Note this measurement. It will be the length of your side strips. Similarly, measure from side to side across the center of the quilt. This will be the length of your top and bottom strips. Cut the number of 3½"-wide strips needed to construct the facing strips. Piece them with diagonal seams as necessary to make 2 side strips and 2 top/bottom strips the exact length needed for your quilt.

### Step 3

Press ½" to the wrong side on one long edge of each strip.

### Step 4

Lay quilt face up on a table. Right sides together, align the unpressed edge of one strip with the corresponding edge of the quilt top, matching centers. Starting at the center, pin the binding to the quilt to within 6 inches of each corner. Continue in this manner until you have pinned the binding strips to all four edges of the quilt top.

### Step 5

Using a 45° triangle ruler, mark the sewing line for the miter at the end of each strip, remembering to add the seam allowance. With right sides together, pin corners and sew the miters without removing the pinned binding from the quilt. Trim off the excess fabric, leaving a ¼" seam allowance.

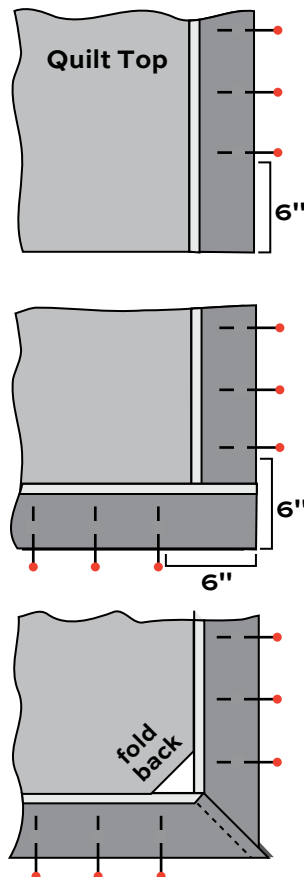

### Step 6

Finger press the seam allowances open and finish pinning the corners to the quilt. Using a walking foot, sew the binding to the quilt using a ⅜" seam all the way around all four sides. Trim the seam allowances at the corners.

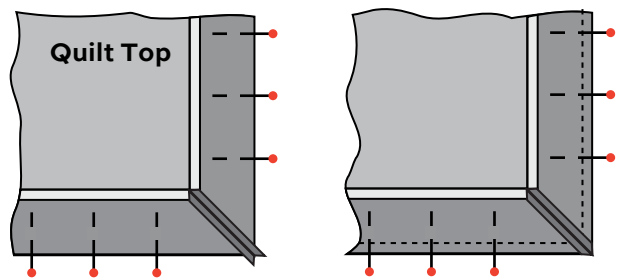

### Step 7

Turn the binding to the back of the quilt, making sure the corners are fully turned to a nice crisp point.

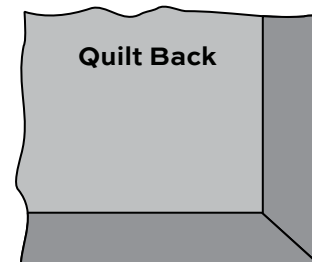

### Step 8

Steam press so the edge is straight and the quilt lies flat. Whip stitch the folded edge to back of quilt by hand, being careful not to let any stitches show through to the front of the quilt.

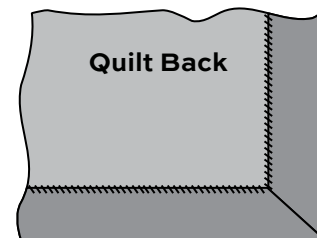

# Geishas and Ginkgos

BY LONNI ROSSI

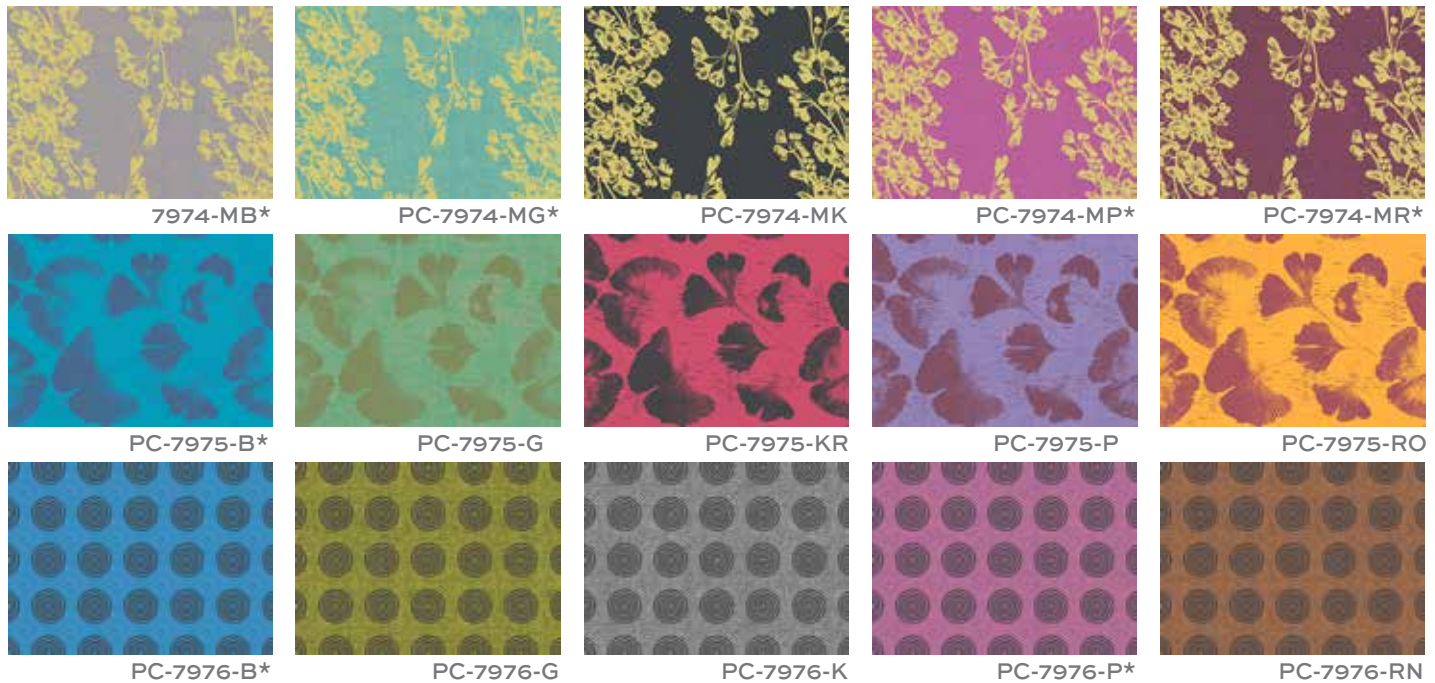

\*Indicates fabrics used in quilt pattern. Fabrics shown are 10% of actual size.

andover

makower uk  
The Henley Studio

Free Pattern Download Available

1384 Broadway New York, NY 10018  
Tel. (800) 223-5678 • andoverfabrics.com